



LOADBARS  
**WIRED**  
**WIRELESS**

Instructions - ENG

Instrucciones para la instalación - ESP

PUBLISHED BY  
Gallagher Group Limited  
181 Kahikatea Drive, Private Bag 3026  
Hamilton, New Zealand

[www.gallagher.com](http://www.gallagher.com)  
Copyright© Gallagher Group Limited 2021  
All rights reserved. Patents pending.

Gallagher Loadbar User Manual

3E1045 - Edition 17 - August 2021

**DISCLAIMER:** Whilst every effort has been made to ensure accuracy, neither Gallagher Group Limited nor any employee of the company shall be liable on any ground whatsoever to any party in respect of decisions or actions they may make as a result of using this information.

In accordance with the Gallagher policy of continuing development, design and specifications are subject to change without notice. Developed and manufactured by Gallagher Group Limited, and ISO 9001 2000 Certified Supplier.

# Contents

English

---

Introduction..... 1

Selecting a location..... 2

    Locating the Scale ..... 2

    Locating the load bars ..... 3

Install the load bars ..... 4

    Adjusting for Corner Variation ..... 5

Care and maintenance..... 7

Specifications..... 8

    Gallagher load bar sets ..... 8

    Cables ..... 8

    Environmental..... 8

    Dimensions - Standard load bars ..... 9

    Dimensions - Heavy Duty load bars ..... 10

Contact details..... 11

Español ..... 13

---



# INTRODUCTION

---

Thank you for purchasing a Gallagher load bar set. Gallagher have been making agricultural weighing equipment for over 20 years and in that time have earned a reputation for quality equipment that withstands tough agricultural conditions.

The Gallagher range of weighing systems is simple, tough, innovative and reliable.

All of the Scales in the Gallagher range can be matched to a choice of load bar systems, as well as a range of platforms and crates to make an accurate and reliable weighing system.

Although designed specifically for agriculture, the Gallagher range is also suited to many industrial applications.

Gallagher WeighScale and Loadbars are not certified for trade use.

# SELECTING A LOCATION

---

Careful preparation of the site is essential if accurate weighing is to result. You need to decide where both the Scale and load bars will be set up.

**For Wired Load bars:** The maximum distance separating the load bars and Scale will be determined by the length of the load bar cables. Choose a route for the cables that ensures they will not be subjected to mechanical damage.

**For Wireless Load bars:** The load bars can be situated up to 10 metres from where the Scale will be operated. This distance will depend on whether there is a clear [signal](#) path between the loadbars and the Scale or mobile device for [uninterrupted](#) connectivity.

Important:

This product is not suitable for use in harsh or corrosive environments (e.g. piggery installations or similar).

## Locating the Scale

Keep the following points in mind when choosing a place for the Scale.

- Do not mount the Scale on the crate.
- Ensure the Scale and its operator do not interfere with the flow of animals.
- Ensure that there is adequate light to read the Scale's screen.
- If you expect to weigh manually, keep the Scale close enough to the crate so that the crate's barrier controls can be easily reached.

## Locating the load bars

Keep the following points in mind when choosing a place for the load bars.

- Mount the load bars and platform clear of obstructions such as fence posts.
- The site must be level.
- Provide a foundation. A concrete pad is recommended. Load bars can be mounted on a heavy board.

Hint: Construct the foundation so that it extends at least 600 mm (23 inches) before the platform. This will force the animals to step onto the foundation before moving on to the weighing platform and will reduce the amount of dirt, mud, or debris carried onto the platform.

- Don't recess the load bars into troughs in the foundation. The troughs are likely to fill with water and mud.

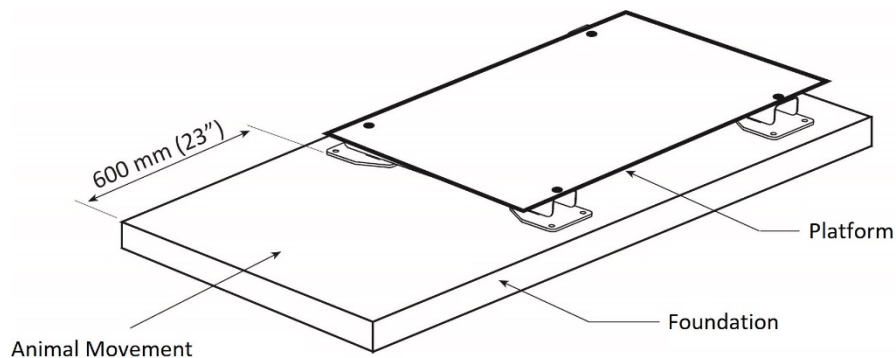

### Notes:

Mounting the load bars on an uneven surface or failing to adequately secure the platform may result in weighing errors.

It is important to ensure the wireless [loadbar](#) modules are kept clear of mud and debris.

## **INSTALLING WIRELESS LOADBARS**



**Important:** Before you install your wireless loadbars, the wireless loadbar modules must be connected to the load bars and turned on.

1. Remove the protective cover from the end of the connector plug extending from one end of each loadbar.
2. Plug **each** orange wireless loadbar module into the **extending connector plug**.
3. Remove the protection tape from the **slide** switch.
4. Turn each module on, by sliding the black switch. (on the top of the module)  
**Note:** Switching on the loadbar module is only done once in the life of the product.
5. Slide the wireless module into the loadbar until it clicks into place.

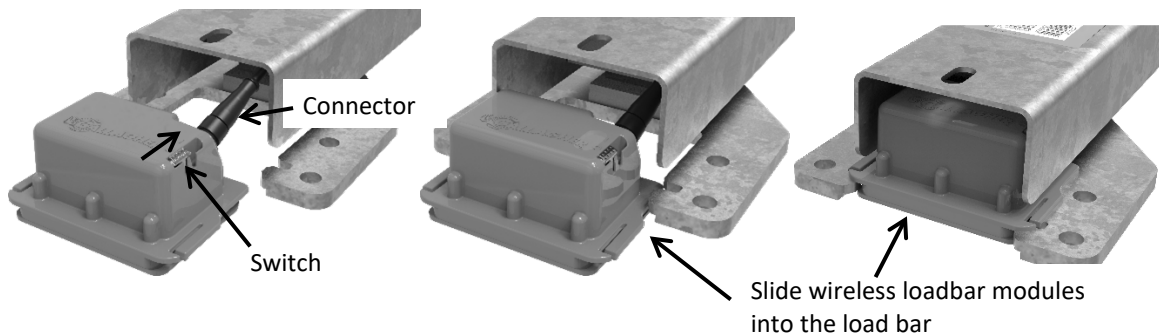

The wireless load bars are now ready for operation with:

- the Gallagher Animal Performance app on your **mobile device**, or
  - the Gallagher TW range of scales.
6. Go to **Installing the Load Bars (p. 10)** for information on how to mount the loadbars on a platform.

---

# INSTALLING THE LOAD BARS

---

**Note:** Do not use an arc welder on either the platform or the load bars. Use of an arc welder may damage the load cells.

1. Position the load bars on the foundation to suit the platform or crate. The load bars should be located as close as possible to the ends of the platform or crate.

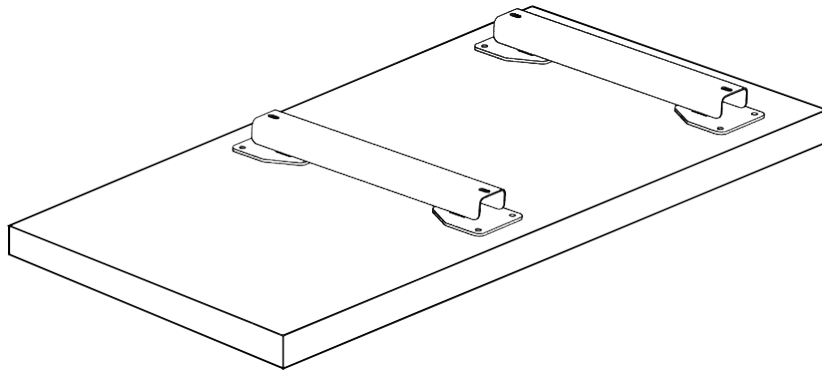

2. Ensure that the load bar feet sit flat on the board or concrete pad.
3. It is recommended that the load bars are secured to the foundation. To secure the load bars, follow these steps.
  - Mark the load bar feet holes on the foundation.
  - Drill and fit fasteners to suit the type of foundation. Dynabolts can be used with concrete foundations; bolts, nuts and washers can be used with board foundations.
  - Tighten the fasteners to secure the load bars to the foundation.

**Note:**

Ensure that the load bar chassis does not twist or distort as the fasteners are tightened. If the load bar feet do not sit flat on the foundation, grout or pack the surface to suit.

4. Attach the crate or platform to the load bars using the fasteners supplied.

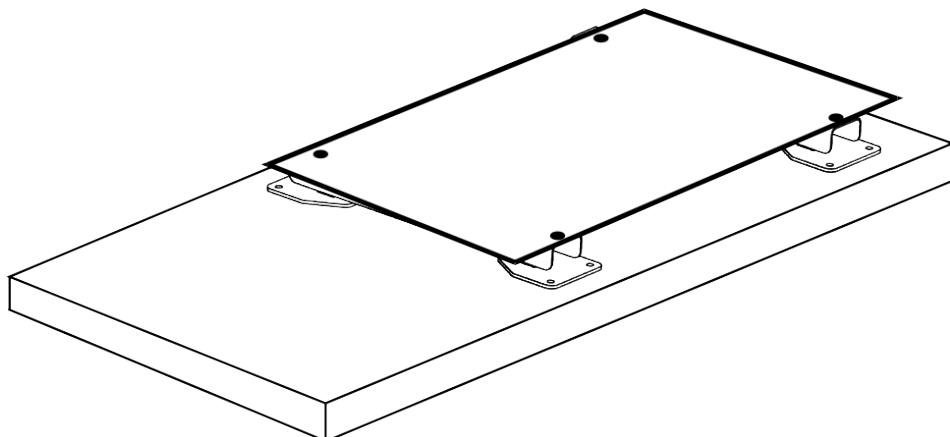



# CARE AND MAINTENANCE

---

Gallagher load bars are designed for use in a livestock environment and are therefore tough and reliable. However proper care and maintenance can extend their life.

Note: This product is not suitable for use in harsh or corrosive environments (e.g.piggery installations or similar)

Below is a list of tips and guidelines for maintaining load bars.

- Although Gallagher load bars are waterproof, it is recommended that they are not submerged in water.
- Cables should be positioned so they will not be stepped on or crushed. Run the cables through a duct to prevent damage.
- To prevent dust or moisture from entering the cables, replace the dust caps immediately after the load bar plugs are disconnected from the Scale,
- Any load bars with damaged cables should be returned to a Gallagher Service Centre for repair. Split or damaged cables can affect the performance of the load bars. If emergency repairs need to be carried out, the damaged cable should be wrapped with insulating tape.
- The platform and load bars should be cleaned up after use. Hose off all dirt and mud to prevent corrosion.

---

**Important:** When cleaning the load bars, do not direct a water blaster in the load cell area.

---

- If the load bars are not permanently installed, they should be stored in a dry place.

**Hint:** Cut the top off a large plastic container, e.g. drench container. Nail the container upside down (i.e. with the opening at the bottom) in the race.

When the load bar cables are not in use, they can be coiled up and hung on a nail inside the container.



**Important For Wireless Loadbars :**

Keep the wireless loadbar modules and the ground area between the loadbar modules, clear of any mud build-up.

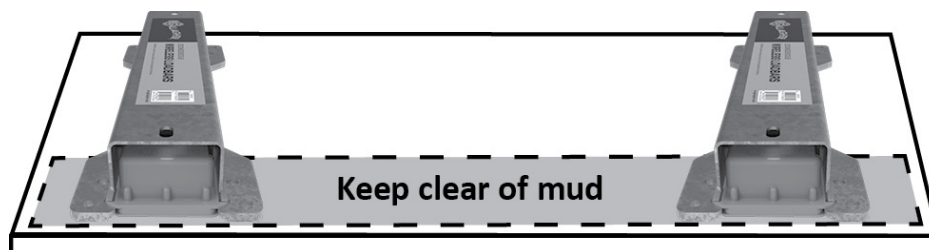

# USING THE WIRELESS LOADBARS

The Gallagher Wireless load bars can be used with:

- the Animal Performance app on your mobile phone or tablet,
- or used with the Gallagher TW scale.

## The Animal Performance app

**Using a mobile or tablet:**

1. Search for and install the **Gallagher Animal Performance** app from Google Play or the App Store.



2. Log in to your existing Gallagher account or select **Sign Up Now** to create an account on the mobile app by following the on-screen prompts.

---

### **Important:**

If you already have an Ag Devices account for your fence, or a log-in for our website please use that.

---

## Connecting the wireless loadbars to the app

1. Open the Animal Performance app and tap on **New Session**. This will create a new session so you can receive weights from the wireless loadbars.
2. Enter a name for the new session, (you could also choose to draft by weight if required) and tap **Done**.
3. The app will then search for the wireless loadbars. When found, the **GGL wireless L/bar** icon appears on your screen.
4. Tap **on** the icon, then tap **Connect** at the bottom of the screen.
 

**Note:** The connection process will take up to 30 seconds **while pairing** between the loadbars and the mobile connection is made.
5. Once connected, the current weight will display as 0.0kg. If it's not 0.0, press the **Zero** button. Apply some weight to the **bars to confirm the connection is working**.
6. You can now start weighing with your Wireless loadbars.



**Note:** The default weighing setting is kg. You can easily change this to pounds from the Main screen, by tapping **Menu > Settings >** then slide the Weight Units from kg to lb.

## Connecting the wireless loadbars to a TW Scale

1. On your TW scale, tap **Settings > Equipment Connections > Loadbars** and select **Wireless**. The TW will start searching for the loadbars.
2. When the wireless loadbars have been located, tap to select them and press **Connect**. **Note:** The connection process will take up to **30 seconds while pairing** between the loadbars and the TW scale.
3. Once connected, tap **Done**. When the wireless loadbars are connected to the TW scale, the Bluetooth icon at the bottom of the screen is activated and turns orange.
4. Create a new session, by tapping **New > Quick Start**. The current weight will display as 0.0kg. If it's not 0.0, press the Zero button. Apply some weight to the **bars to confirm the connection is working**.

# SPECIFICATIONS – WIRED LOADBARS

## Gallagher Wired load bar sets

The following specifications apply to a set of two load bars.

1500 kg load bar set	
Overall length:	580 mm (22.83 inches)
Weight (including cables)	17 kg (38 lb)
Capacity:	1500 kg (3300 lb)

2500 kg load bar set (Standard)	
Overall length:	660 mm (25.98 inches); or 1060 mm (41.73 inches)
Weight (including cables)	600mm bars - 17 kg (38 lb) 1000mm bars – 25kg (55 lb)
Capacity:	2500 kg (5500 lbs)

5000 kg load bar set (Heavy Duty)	
Overall length	1060 mm (41.73 inches)
Weight (including cables)	55 kg (122 lb)
Capacity:	5000 kg (11000 lb)

## Cables

Length: 6 m (19.6 feet)

## Environmental

Operating temperature:	-20 to 50°C -4 to 122°F
------------------------	-------------------------

## Dimensions - 1500 kg load bars

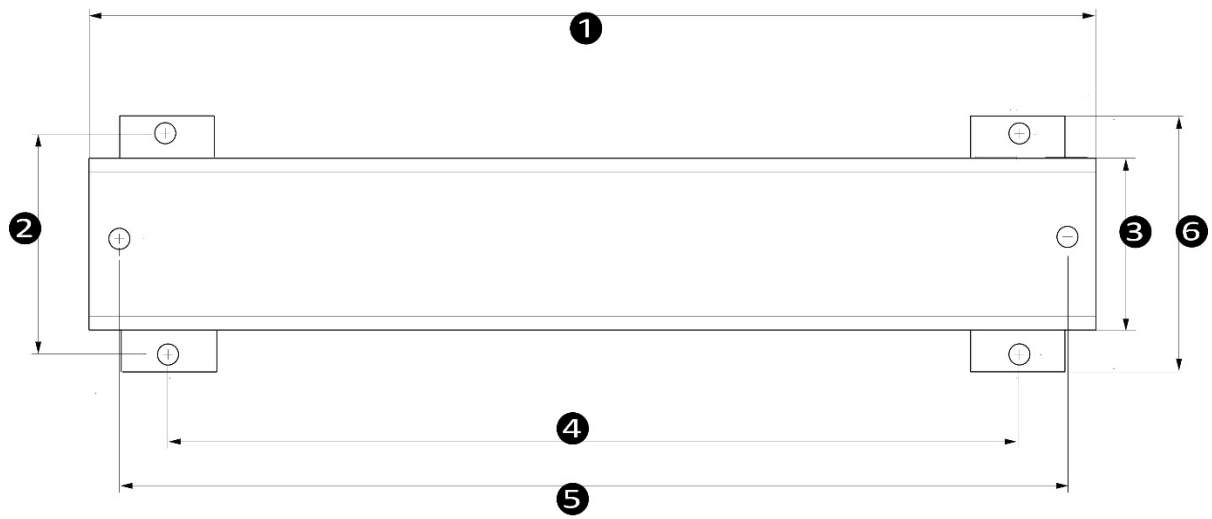

Key	(mm)	(inches)
1	125	4.92
2	580	22.83
3	480	18.90
4	558	21.97
5	95	3.74
6	150	5.90
Height	95	5.90

## Dimensions - 2500 kg Standard load bars

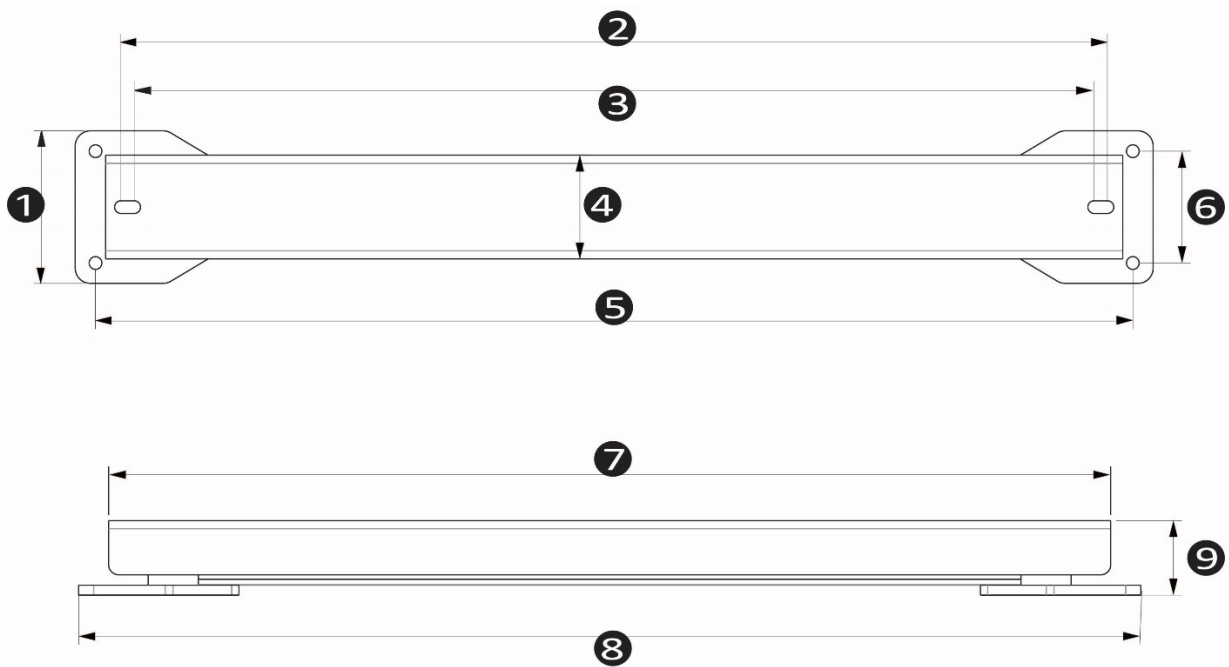

Key	600 mm (23 inch) Load bar		1000 mm (39 inch) Load bar	
	(mm)	(inches)	(mm)	(inches)
1	150	5.91	150	5.91
2	570	22.44	970	38.19
3	544	21.42	944	37.17
4	102	4.02	102	4.02
5	620	24.41	1020	40.16
6	110	4.33	110	4.33
7	600	23.62	1000	39.37
8	660	25.98	1060	41.73
9	75	2.95	75	2.95

## Dimensions - 5000 kg Heavy Duty load bars

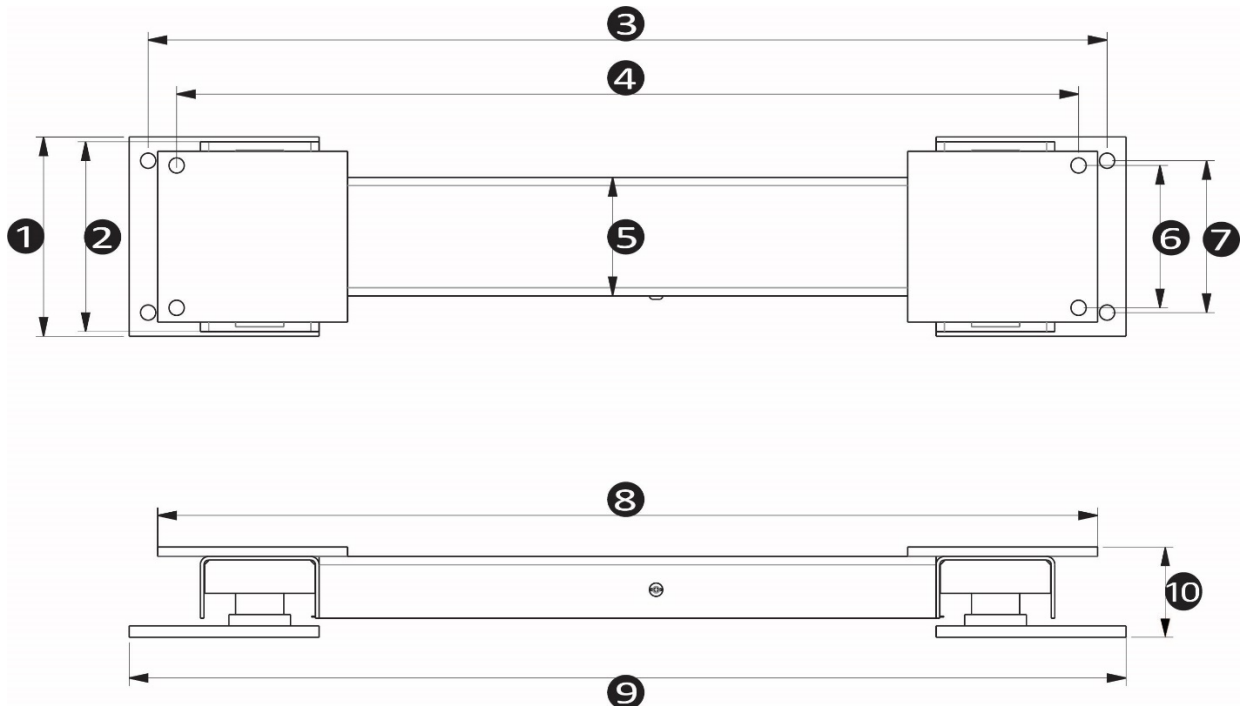

Key	(mm)	(inches)
1	210	8.27
2	200	7.87
3	1010	39.76
4	950	37.4
5	102	4.02
6	150	5.91
7	160	6.3
8	990	38.98
9	1050	41.34
10	95.1	3.74

# SPECIFICATIONS – WIRELESS LOAD BARS

## Gallagher Wireless Load Bar sets

The following specifications apply to a set of two load bars.

2500 kg load bar set (Standard)	
Overall length:	660 mm (25.98 inches); or 1060 mm (41.73 inches)
Weight	600mm bars -17 kg (38 lb) 1000mm bars – 25 kg (55 lb)
Capacity:	2500 kg (5500 lb)

5000 kg load bar set (Heavy Duty)	
Overall length	1060 mm (41.73 inches)
Weight	55 kg (122 lb)
Capacity:	5000 kg (11000 lb)



## Dimensions - 2500 kg Standard Wireless Load Bars

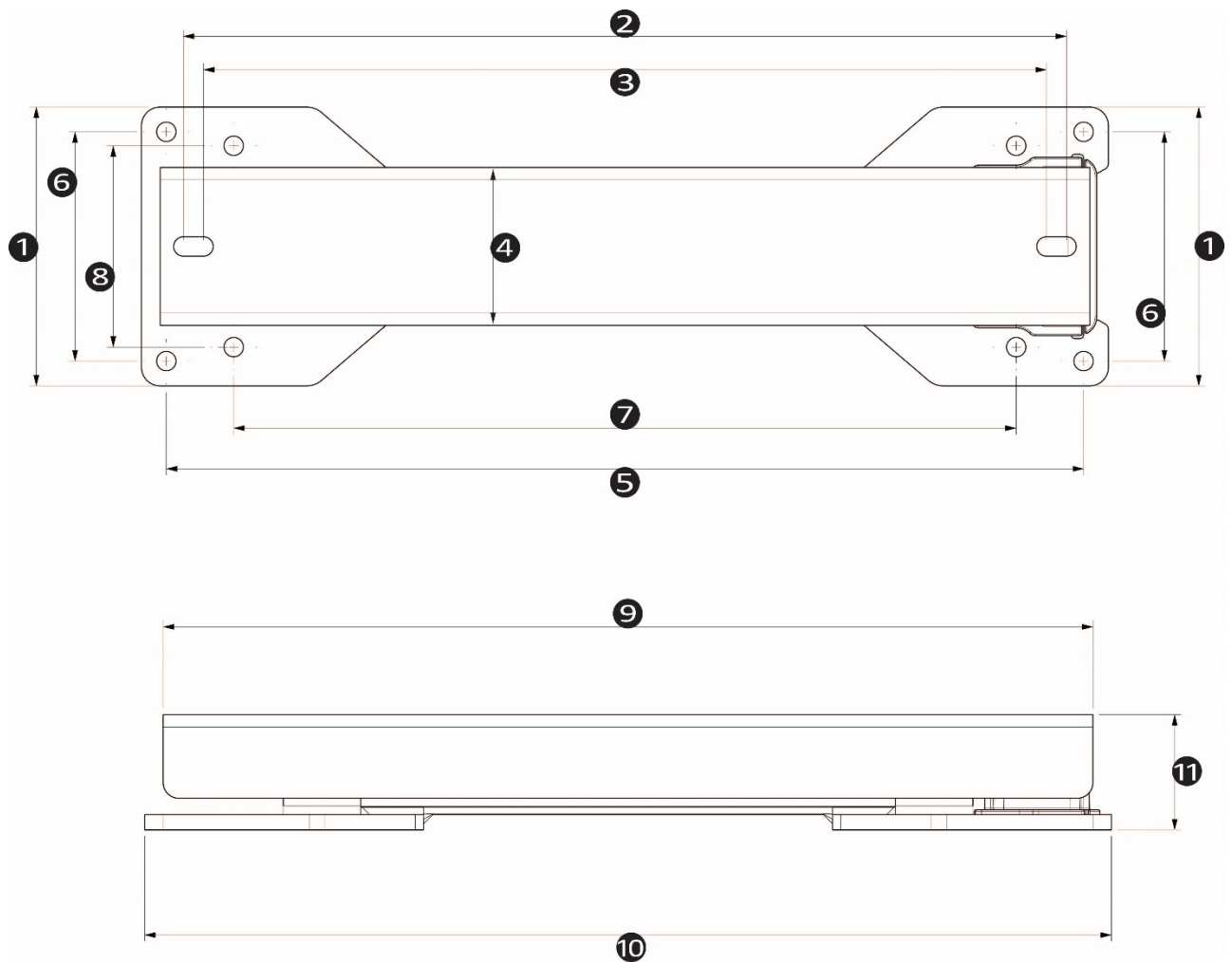

Key	600 mm (23 inch) Load bar		1000 mm (39 inch) Load bar	
	(mm)	(inches)	(mm)	(inches)
1	180	7.08	180	5.91
2	570	22.44	970	38.19
3	544	21.42	944	37.17
4	102	4.02	102	4.02
5	505	19.88	905	35.63
6	592	23.30	992	39.05
7	148	5.82	148	5.82
8	130	5.12	130	5.12
9	600	23.62	1000	39.37
10	624	24.56	1024	40.31
11	75	2.95	75	2.95

## Dimensions - 5000kg Heavy Duty Wireless Load Bars

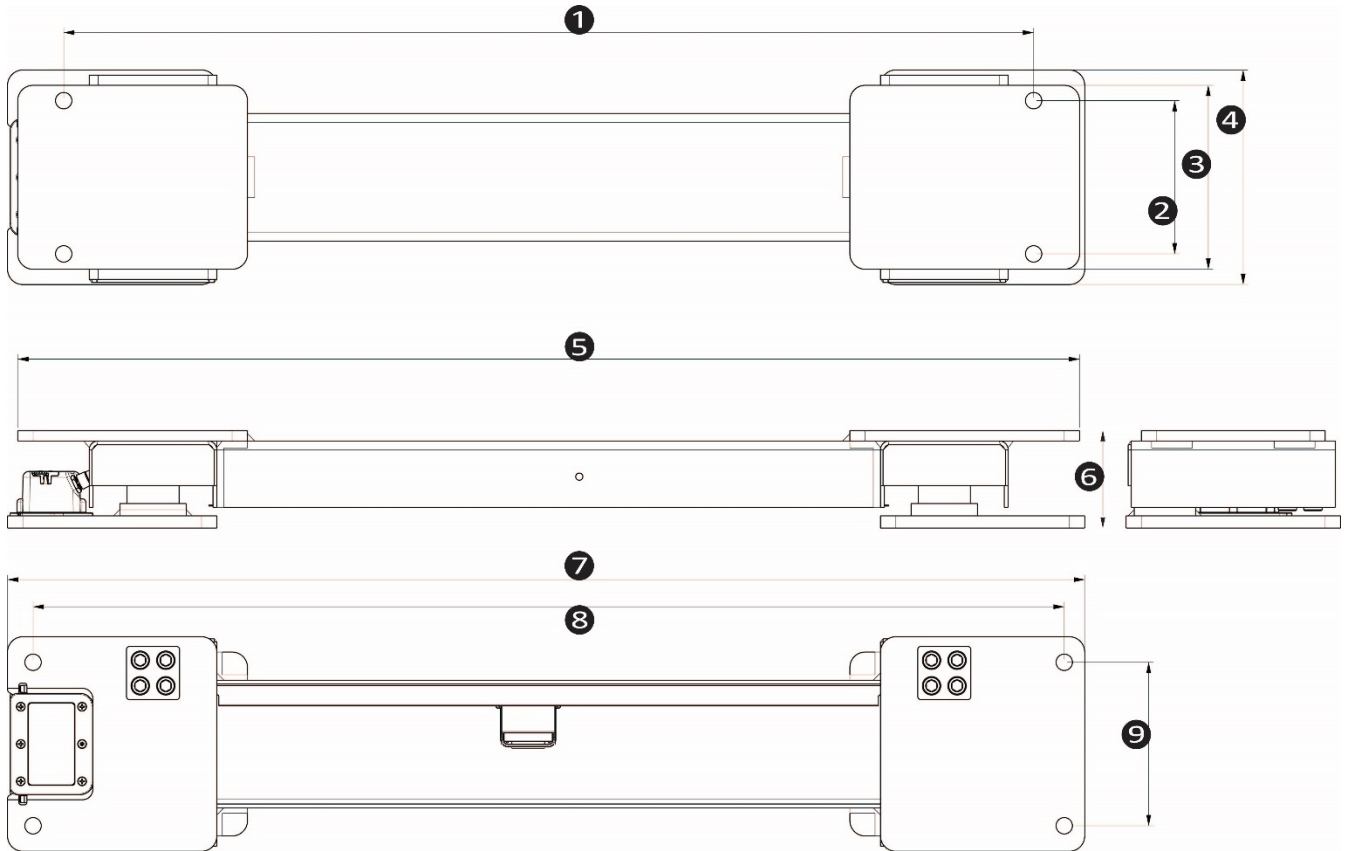

Key	(mm)	(inches)
1	950	37.40
2	150	5.90
3	180	7.08
4	210	8.27
5	1040	40.94
6	148	5.82
7	1055	41.53
8	1010	39.76
9	180	7.08

## CONTACT DETAILS

---

The Gallagher range of products is distributed by the following companies:

### NEW ZEALAND

Gallagher Group Ltd,  
181 Kahikatea Drive,  
Private Bag 3026  
Hamilton 3240

### UNITED KINGDOM

Gallagher Power Fence™ (UK) Ltd,  
Unit 5, Eastboro Fields,  
Hemdale Business Park,  
Attleborough,  
Nuneaton CV11 6GL.

### IRELAND

Gallagher Power Fence Systems  
(IRL) Ltd,  
Kinsale Road,  
Cork

### NORTHERN IRELAND

Sam Nelson & Son,  
16 Lower Ballinderry Road,  
Upper Ballinderry,  
Lisburn, Co. Antrim BT28 2JB.

### SOUTH AFRICA

Rudd Products,  
Bush Willows, 24 Begonia Road,  
Kyalami, Johannesburg,  
Gauteng, 1684

### USA/ CANADA

Gallagher USA Inc,  
130 W 23rd Avenue,  
North Kansas City.  
MO 64116 Missouri

### EUROPE

Gallagher Europe Bv,  
Hekum 9, 9774 TH, Adorp (Gn),  
Netherlands

### AUSTRALIA

Gallagher Australia Pty Ltd,  
14 Somerton Park Drive,  
Campbellfield,  
Melbourne, Victoria, 3061